

Parte incasso monocomando doccia INCASSO_ZB002300

MODELLO **ZB002300**

Parte incasso monocomando 2 uscite, doccia incasso 1/2", senza parte esterna



FINITURE DISPONIBILI



04 04 Senza Finitura

CARATTERISTICHE

Installazione	Incasso
Ricambio Cartuccia	ZZ92909000
Cartuccia Monocomando 43 mm	
Incasso	1

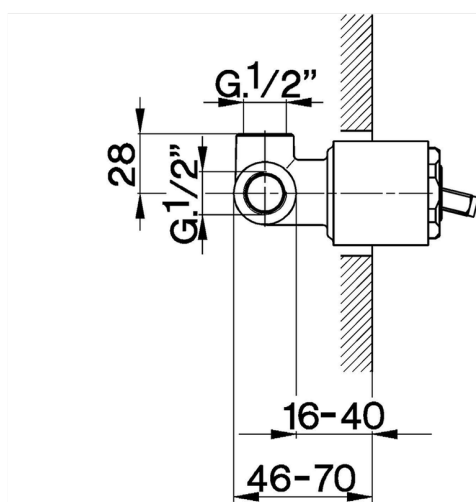

2026-06-30