

## Parte incasso termostatico doccia 2 uscite INCASSO\_ZB019100

MODELLO **ZB019100**

Parte incasso termostatico doccia 2 uscite, con deviasp 2 uscite 1/2", senza parte esterna

FINITURE DISPONIBILI



**04** 04 Senza Finitura



CARATTERISTICHE

Installazione	<b>Incasso</b>
Ricambio Cartuccia	<b>24.04A.PP</b>
<b>Cartuccia Termostatica Plus P 8X20</b>	
Incasso	<b>1</b>

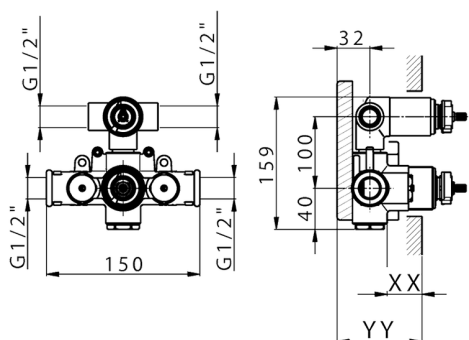

Piastra/Plate/Plaque/Platte/Placa  
 2-3mm: XX 25-40 YY 76-91  
 10mm: XX 21-34 YY 70-83



### Termostatico

Il Termostatico Huber è il tuo personale gestore dell'acqua che ti aiuta a gestire e controllare acqua ed energia senza sprechi.



## Parte incasso termostatico doccia 2 uscite INCASSO\_ZB019100

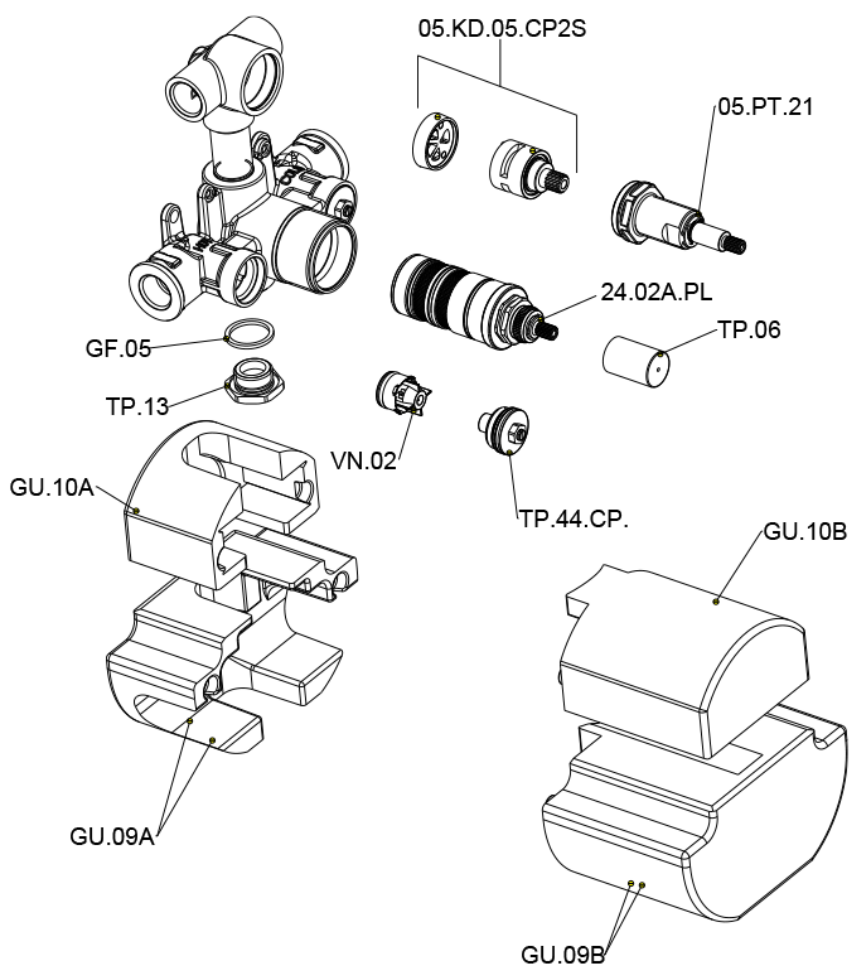

ZB019100

<https://www.huberitalia.com/parte-incasso-termostatico-doccia-2-uscite-incasso-zb019100>

2026-06-29