

Set doccetta igienica completo COLLETTIVITÀ_H3007925



MODELLO **H3007925**

Set doccetta igienica completo, supporto murale tondo, apertura acqua singola, doccetta igienica in ABS, flex PVC 120 cm

FINITURE DISPONIBILI



CARATTERISTICHE

Doccetta igienica

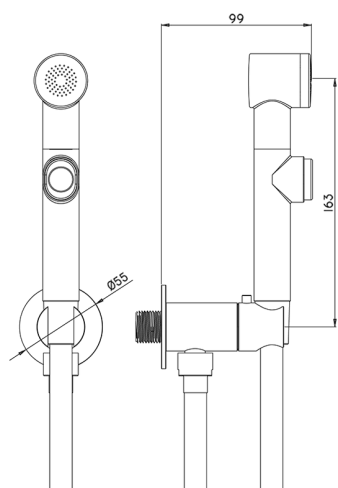

Doccetta Igienica

Doccetta igienica multiforo, per la cura dell'igiene personale.



2026-04-18